

JOB:	REPRESENTATIVE:
UNIT TAG:	ORDER NO.
ENGINEER:	SUBMITTED BY:
CONTRACTOR:	APPROVED BY:
	DATE:
	DATE:
	DATE:

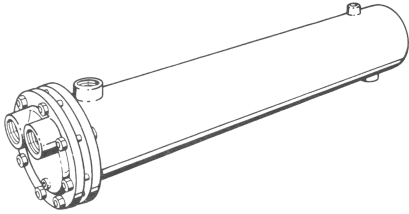

6" Series Type "WU" Heat Exchangers "U" Tube Design

DESCRIPTION

B & G Types "WU" Heat Exchangers are of the shell and tube type. The tube bundle is of "U" bend construction with tube ends expanded into a stationary tube sheet. This construction permits ample expansion or contraction for wide temperature variations. A fluid entering the tubes is heated or cooled by a fluid being circulated through a baffled shell. The unit is designed primarily for pumped circulation through the shell.

Standard "WU" Heat Exchangers are constructed according to ASME requirements for pressure and temperatures noted in table on back.

A Manufacturers' Data Report for Pressure Vessels, Form No. U-1, as required by the provisions of the ASME Code Rules, is furnished with each unit upon request. This form is signed by an authorized inspector, holding a national Board Commission, and who is employed by an authorized inspection agency, certifying that construction conforms to the latest ASME code for pressure vessels. The ASME "U" symbol is stamped on each vessel. In addition, each unit is registered with the national Board of Boiler and pressure Vessel Inspectors.

RECOMMENDED "WU" HEAT EXCHANGER

MODEL NO. _____

HEATING SURFACE (SQ. FT.) _____

	TUBE SIDE	SHELL SIDE
1. Fluid Circulated.....	_____	_____
2. Total Flow Expressed in GPM, GRH or lbs./hr.....	_____	_____
3. Temperature In/Out.....	_____ / _____	_____ / _____
4. Transfer BTU/hr.....	_____	_____
5. Pressure Drop.....	_____	_____
6. Fouling Factor or Percentage of Additional Surface.....	_____	_____
Note: Following applies only to fluids other than water		
7. Specific Gravity.....	_____	_____
8. Specific Heat.....	_____	_____
9. Latent Heat.....	_____	_____
10. Viscosity**.....	_____	_____
11. Thermal Conductivity.....	_____	_____

APPROVALS

**Expressed in Proper Units and Temperature such as centipoises @ °F

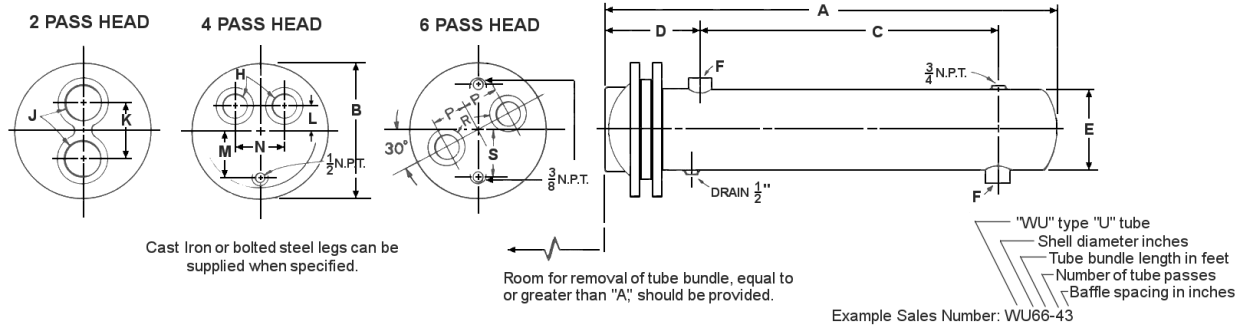

DIMENSIONS - Inches (mm)

UNIT NUMBER	2 PASS								HEATING SURFACE Sq. Ft. (Sq. M)	APPROX. SHIPPING Wt. Lbs. (Kg)
	J	K	A	B	C	D	E	F		
WU63-23	2 NPT	3-3/4 (95)	40-1/8 (1019)	10-1/2 (267)	27-1/2 (698)	6-7/8 (175)	6-5/8 (168)	2-1/2 NPT	12.7 (1.2)	125 (57)
WU64-23	2 NPT	3-3/4 (95)	52-1/8 (1324)	10-1/2 (267)	39-1/2 (1003)	6-7/8 (175)	6-5/8 (168)	2-1/2 NPT	17.4 (1.6)	150 (68)
WU65-23	2 NPT	3-3/4 (95)	64-1/8 (1629)	10-1/2 (267)	51-1/2 (1308)	6-7/8 (175)	6-5/8 (168)	2-1/2 NPT	22.1 (2.1)	175 (79)
WU66-23	2 NPT	3-3/4 (95)	76-1/8 (1934)	10-1/2 (267)	63-1/2 (1613)	6-7/8 (175)	6-5/8 (168)	2-1/2 NPT	26.8 (2.5)	200 (91)
WU67-23	2 NPT	3-3/4 (95)	88-1/8 (2238)	10-1/2 (267)	75-1/2 (1918)	6-7/8 (175)	6-5/8 (168)	2-1/2 NPT	31.5 (2.9)	225 (102)
WU68-23	2 NPT	3-3/4 (95)	100-1/8 (2543)	10-1/2 (267)	87-1/2 (2222)	6-7/8 (175)	6-5/8 (168)	2-1/2 NPT	36.2 (3.4)	250 (113)

UNIT NUMBER	4 PASS										HEATING SURFACE Sq. Ft. (Sq. M)	APPROX. SHIPPING Wt. Lbs. (Kg)
	H	L	M	N	A	B	C	D	E	F		
WU63-43	1-1/2 NPT	1-19/32 (40)	2-13/16 (71)	3-3/16 (81)	40-1/8 (1019)	10-1/2 (267)	27-1/2 (698)	6-7/8 (175)	6-5/8 (168)	2-1/2 NPT	12.7 (1.2)	125 (57)
WU64-43	1-1/2 NPT	1-19/32 (40)	2-13/16 (71)	3-3/16 (81)	52-1/8 (1324)	10-1/2 (267)	39-1/2 (1003)	6-7/8 (175)	6-5/8 (168)	2-1/2 NPT	17.4 (1.6)	150 (68)
WU65-43	1-1/2 NPT	1-19/32 (40)	2-13/16 (71)	3-3/16 (81)	64-1/8 (1629)	10-1/2 (267)	51-1/2 (1308)	6-7/8 (175)	6-5/8 (168)	2-1/2 NPT	22.1 (2.1)	175 (79)
WU66-43	1-1/2 NPT	1-19/32 (40)	2-13/16 (71)	3-3/16 (81)	76-1/8 (1934)	10-1/2 (267)	63-1/2 (1613)	6-7/8 (175)	6-5/8 (168)	2-1/2 NPT	26.8 (2.5)	200 (91)
WU67-43	1-1/2 NPT	1-19/32 (40)	2-13/16 (71)	3-3/16 (81)	88-1/8 (2238)	10-1/2 (267)	75-1/2 (1918)	6-7/8 (175)	6-5/8 (168)	2-1/2 NPT	31.5 (2.9)	225 (102)
WU68-43	1-1/2 NPT	1-19/32 (40)	2-13/16 (71)	3-3/16 (81)	100-1/8 (2543)	10-1/2 (267)	87-1/2 (2222)	6-7/8 (175)	6-5/8 (168)	2-1/2 NPT	36.2 (3.4)	250 (113)

UNIT NUMBER	6 PASS									HEATING SURFACE Sq. Ft. (Sq. M)	APPROX. SHIPPING Wt. Lbs. (Kg)
	P	R	S	A	B	C	D	E	F		
WU63-63	2-13/16 (71)	1-1/4 NPT	2-13/16 (71)	40-1/8 (1019)	10-1/2 (267)	27-1/2 (698)	6-7/8 (175)	6-5/8 (168)	2-1/2 NPT	9.6 (0.9)	125 (57)
WU64-63	2-13/16 (71)	1-1/4 NPT	2-13/16 (71)	52-1/8 (1324)	10-1/2 (267)	39-1/2 (1003)	6-7/8 (175)	6-5/8 (168)	2-1/2 NPT	13.1 (1.2)	150 (68)
WU65-63	2-13/16 (71)	1-1/4 NPT	2-13/16 (71)	64-1/8 (1629)	10-1/2 (267)	51-1/2 (1308)	6-7/8 (175)	6-5/8 (168)	2-1/2 NPT	16.7 (1.6)	175 (79)
WU66-63	2-13/16 (71)	1-1/4 NPT	2-13/16 (71)	76-1/8 (1934)	10-1/2 (267)	63-1/2 (1613)	6-7/8 (175)	6-5/8 (168)	2-1/2 NPT	20.2 (1.9)	200 (91)
WU67-63	2-13/16 (71)	1-1/4 NPT	2-13/16 (71)	88-1/8 (2238)	10-1/2 (267)	75-1/2 (1918)	6-7/8 (175)	6-5/8 (168)	2-1/2 NPT	23.8 (2.2)	225 (102)
WU68-63	2-13/16 (71)	1-1/4 NPT	2-13/16 (71)	100-1/8 (2543)	10-1/2 (267)	87-1/2 (2222)	6-7/8 (175)	6-5/8 (168)	2-1/2 NPT	27.3 (2.5)	250 (113)

Dimensions are subject to change. Not to be used for construction purposes unless certified.

**DESIGN PRESSURES - ASME CONSTRUCTION
CAST IRON & BRASS UNITS**

DESIGN PRESSURES				DESIGN TEMPERATURES*	
TUBE SIDE		SHELL SIDE		TUBE & SHELL SIDE	
DESIGN	TEST	DESIGN	TEST	CAST IRON	BRASS
150 psi (10 bar)	300 psi (20 bar)	150 psi (10 bar)	300 psi (20 bar)	375°F (190°C)	300°F (149°C)

*For design pressures and temperatures higher than shown, consult B & G Representative for specifications and dimensions.

Caution: A properly sized relief valve must be installed on the heated side to protect heat exchangers from possible damage due to volumetric expansion.

MATERIALS

PART	STANDARD CAST IRON UNIT	BRASS UNIT
	2, 4 & 6 Pass	2 & 4 Pass
Shell	Steel	Steel
Head	Cast Iron	Cast Brass
Tubes 3/4" O.D.	Cooper	Cooper
Tubesheets	Steel	Royal Naval Brass
Baffles	Steel	Steel
Nuts & Bolts	Steel	Steel

Xylem Inc.
8200 N. Austin Avenue
Morton Grove, IL 60053
Phone: (847)966-3700
Fax: (847)965-8379
www.bellgossett.com

